

# Exhaustive Search for Quantum Circuit Optimization using ZX Calculus

Tobias Fischbach<sup>1</sup> Pierre Talbot<sup>1</sup> Pascal Bouvry<sup>1</sup>

<sup>1</sup>University of Luxembourg, Department of Computer Science

## Abstract

- Quantum computers offer major speed-ups but are limited by qubit availability, short coherence, and high error rates.
- ZX calculus offers a semantic preserving rewriting system independent of the chosen gate set.
- The combination of exhaustive search and ZX calculus allows for metric agnostic optimization of quantum circuits.
- Pruning conditions are necessary to handle the non-terminating nature of ZX calculus.
- Benchmark on 100 standard circuits with a PyZX and Qiskit integration.

## Background

ZX calculus is a diagrammatic reasoning framework for quantum circuits that is [6]:

- Compact:** small number of elementary building blocks and rewriting rules.
- Complete:** rewriting rules are semantic preserving.
- Universal:** any quantum circuit can be represented as a ZX diagram.

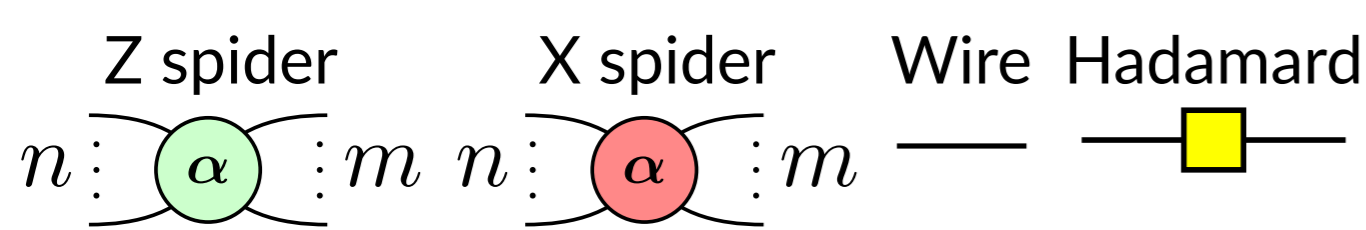

Figure 1. Generators of ZX calculus.

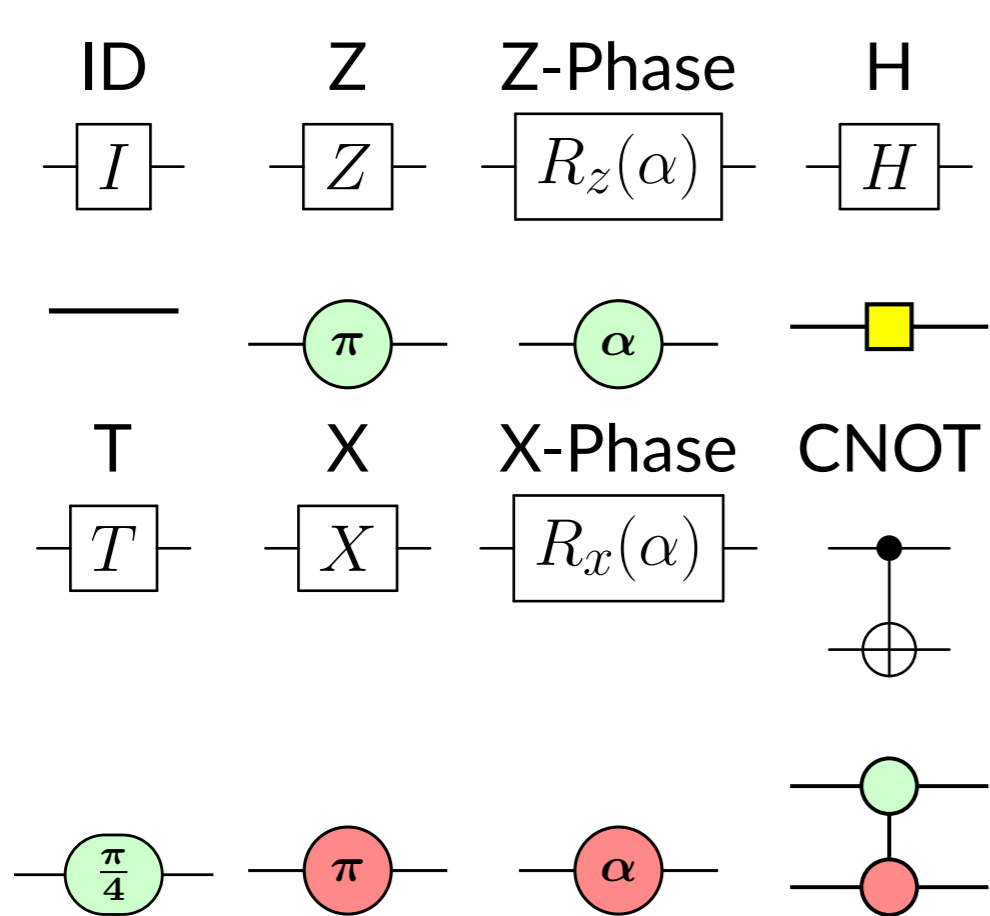

Figure 2. Translation from gates to generators.

**Only topology matters.** Bending wires do not change the ZX diagram's linear map.

**Non-terminating rewriting system.** Some rules are always applicable.

## References

- [1] Backens et al. "There and back again: A circuit extraction tale". In: (Mar. 2021).
- [2] Beaudrap et al. "Circuit Extraction for ZX-Diagrams Can Be #P-Hard". In: ed. by Mikolaj Bojanczyk et al. Dagstuhl, Germany: Schloss Dagstuhl – Leibniz-Zentrum für Informatik, 2022.
- [3] Mattick et al. *Optimizing Quantum Circuits via ZX Diagrams using Reinforcement Learning and Graph Neural Networks*. 2025.
- [4] Nägele et al. "Optimizing ZX-diagrams with deep reinforcement learning". In: (Sept. 2024).
- [5] Riu et al. "Reinforcement Learning Based Quantum Circuit Optimization via ZX-Calculus". In: (May 2025).
- [6] van de Wetering. *ZX-calculus for the Working Quantum Computer Scientist*. Dec. 2020. (Visited on 02/23/2024).

## Methodology

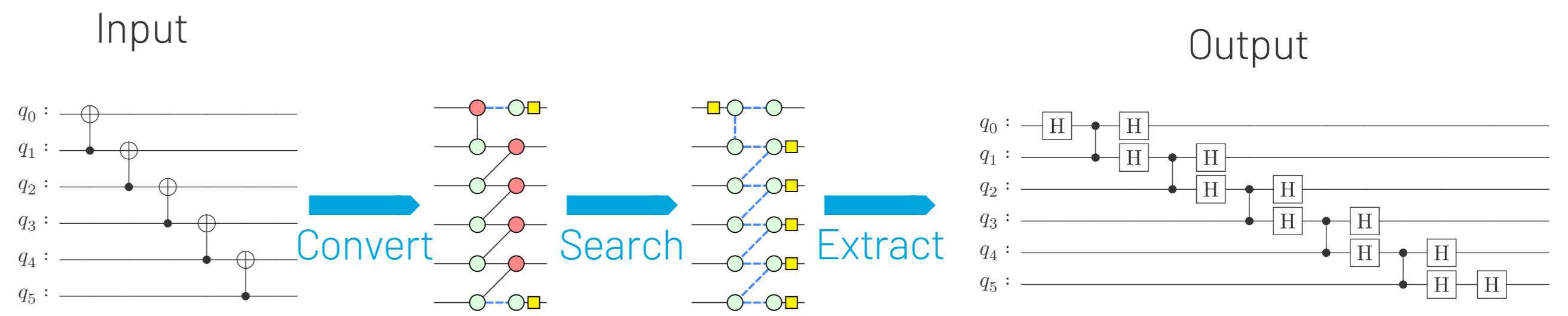

- Benchmark consists of 100 standard quantum circuits.
- Compare Depth-first search (DFS) and iterative deepening DFS (IDDFS) with SOTA.
- Disallowed repeated application of the color change rule.
- All possible modifications of a rewriting rule are applied in a batch.
- No spider unfusion.
- Set a global time limit of 1.5 hours.
- Connectivity change takes precedent over spider count.

## Results

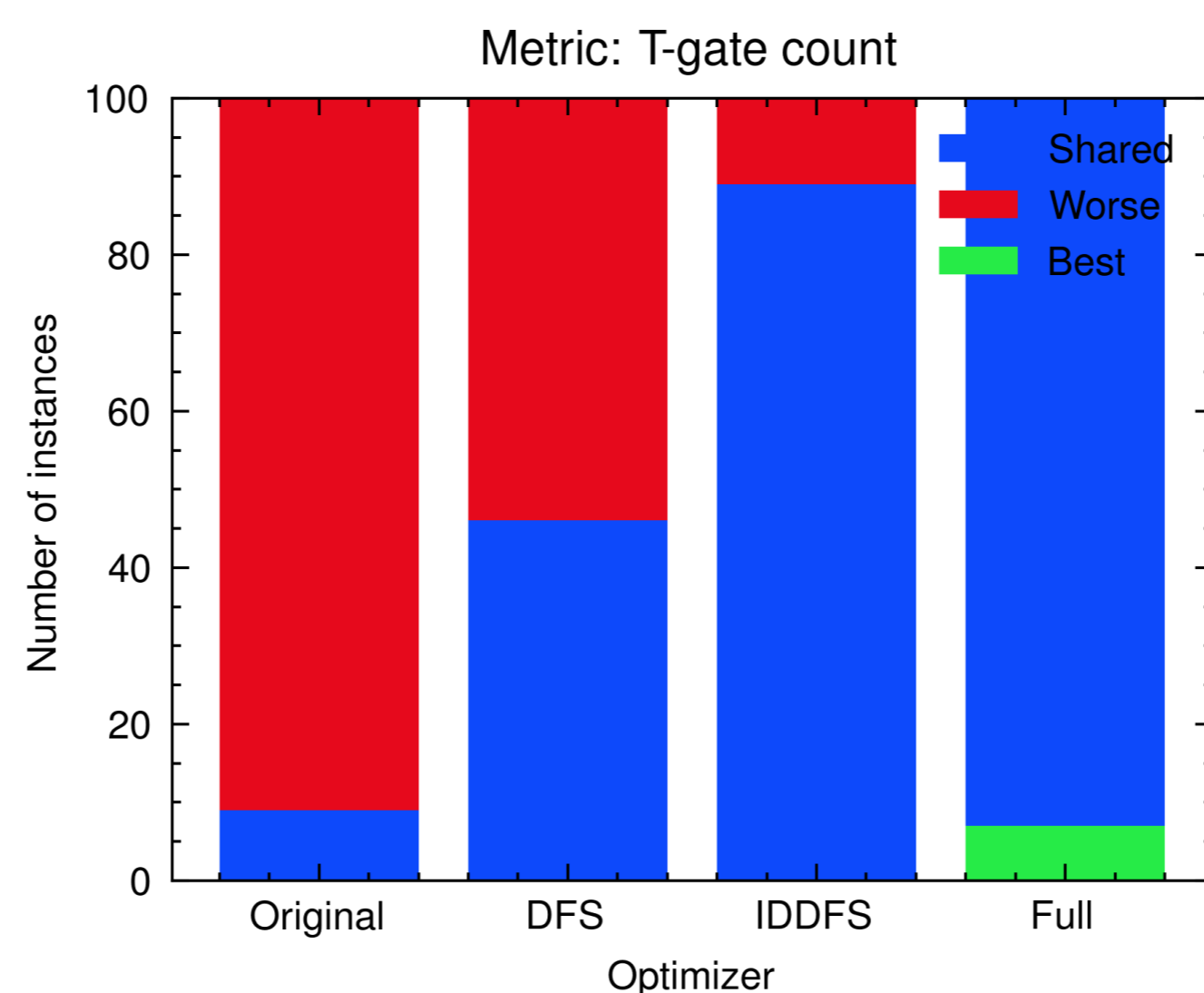

- DFS equates T-gate count of Full reduce on 46% of the instances.
- DFS has the best edge count on 32% of the instances.
- IDDFS equates T-gate count of Full reduce on 89% of the instances.
- IDDFS has the best edge count on 86% of the instances.
- Full reduce always leads to the best result of the T-gate count.
- Full reduce has the best edge count on 15% of the instances.

- Solution strongly depends on circuit extraction algorithm (#P-hard) [1, 2].
- Edge count reduction not necessarily translates into 2Q-gate reduction.
- Exhaustive search is general but does not scale for larger circuits.

Algorithm	T-gate	Edges
DFS	-10%	-11%
IDDFS	-26%	-22%
Full reduce	-27%	-2%

## Challenges

- High memory requirements:** Real-world quantum circuits result in large ZX diagrams with high memory requirements for every state.
- Non-terminating:** Infinite rewriting sequences exist.
- Failed states:** The extraction of ZX diagrams to quantum circuit might fail (or be prohibitively long) with current algorithms. Checking if a diagram is extractable is time consuming and prevents us from exploring a large number of nodes.

## Can AI help?

Current efforts focus around Reinforcement-Learning (RL):

- General RL framework without the consideration of circuit extraction [4].
- RL framework that treats circuit extraction as a black box [5].
- RL replaces the heuristic inside a tree search [3].

**Let's discuss! What are your thoughts?**

